

A

B

C

D

E

F

REV	ECN No.	DESCRIPTION	DESIGN	DATE
A0		Release	李润	2016.07.01

1

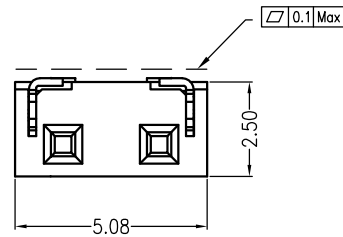

2

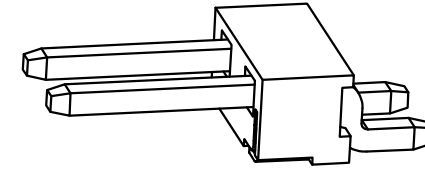
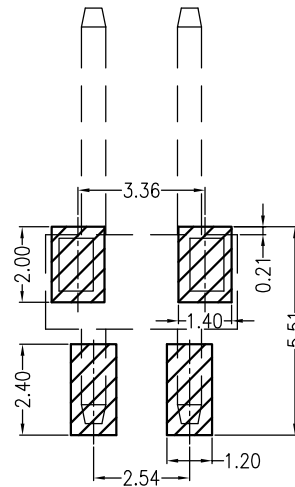

主要技术参数 Main Specifications

线 数 (Poles): 02 to 04

接触电阻 (Contact resistance): $\leq 20m\Omega$

绝缘电阻 (Insulation resistance): $\geq 1000M\Omega$

额定电压 (Rated voltage): 125V AC DC

额定电流 (Rated current): 1.0A AC DC

耐 电压 (Withstand Voltage): 1000V AC/minute

温度范围 (Temperature Range): $-25^{\circ}C \sim +105^{\circ}C$

ORDER INFORMATION:

L015AWR-02-F2MA2-R			
PART No.		PACKAGING:	P=PE R=REEL
No. FOR CIRCUITS:	02	Metal material:	2=Brass
PLASTIC MATERIAL:	F2M=LCP (BEIGE)	PLATING:	A=Sn

3

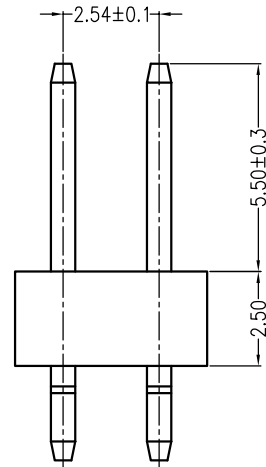

4

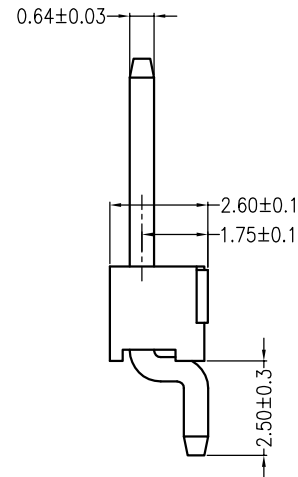

5

A

B

C

D

E

F

ITEM	COMPONENT	Q'TY	MATERIAL	FINISH
C	Solder Tab	2 PCS	PhosphorBronze	Sn-plated
B	CONTACT	2 PCS	Brass	Sn-plated
A	PEDESTAL	1 PCS	LCP	UL 94V-0, COLOR:BEIGE

 东莞市高迪电子有限公司
DONG GUAN GAO DI ELECTRONICS CO., LTD

TITLE: L015AWR-02-01*
2.54mmPITCH 90°WAFER SMT TYPE

X.±0.5	X.±5'	USE: CUSTOMER	PART NO.:	
.X±0.3	.X±2'		L015AWR-02-F2MA2-R	
.XX±0.25	.XX±1'	APPD:	DWG NO.:	
--	--	CHKD:	GCCP-0251	
	UNITS: mm	DR: 蒋建银	SCALE 1 : 1	SHEET 1 / 1

A B C D

E F

REV	ECN No.	DESCRIPTION	DESIGN	DATE
A0		Release	蒋建银	2018.11.14

1
2
3
4
5

1
2
3
4
5

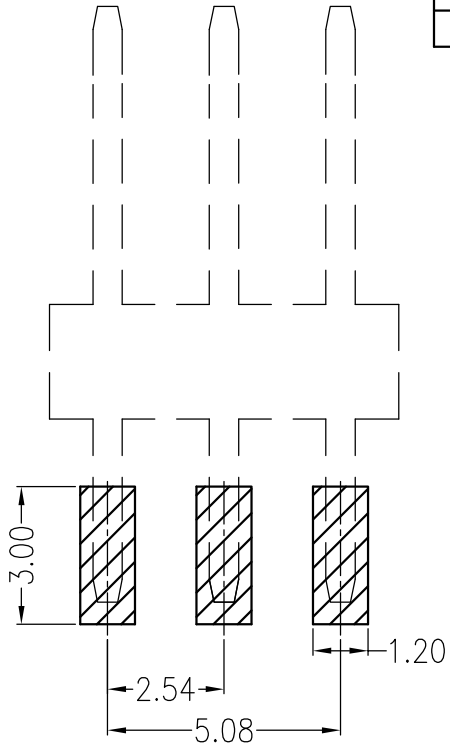
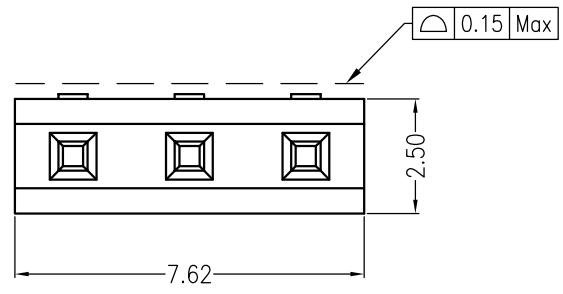

主要技术参数 Main Specifications

线 数 (Poles): 02 to 04
 接触电阻 (Contact resistance): $\leq 20m\Omega$
 绝缘电阻 (Insulation resistance): $\geq 1000M\Omega$
 额定电压 (Rated voltage): 125V AC DC
 额定电流 (Rated current): 1.0A AC DC
 耐电压 (Withstand Voltage): 1000V AC/minute
 温度范围 (Temperature Range): $-25^{\circ}C \sim +105^{\circ}C$

ORDER INFORMATION:

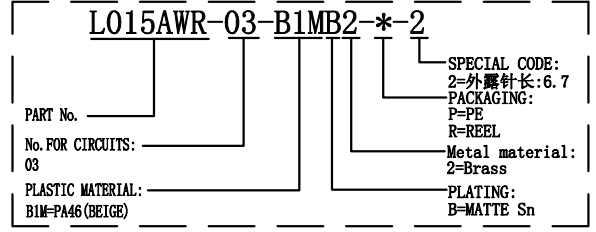

Board Layout
 General Tolerance: ± 0.05

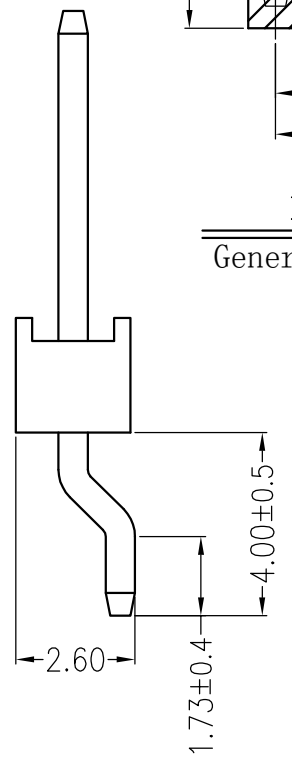
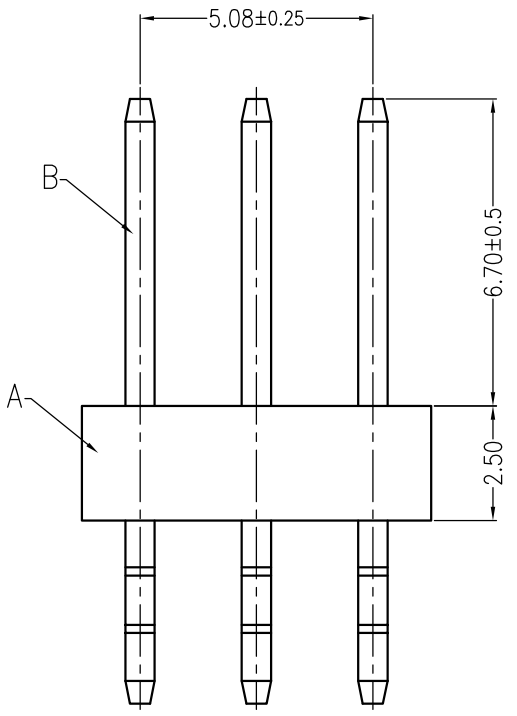

ITEM	COMPONENT	Q'TY	MATERIAL	FINISH
C				
B	CONTACT	3 PCS	Brass	MATTE Sn-plated
A	PEDESTAL	1 PCS	PA46	UL 94V-0, COLOR:BEIGE

东莞市高迪电子有限公司
 DONG GUAN GAO DI ELECTRONICS CO., LTD

TITLE: -
 2.54mmPITCH 90°WAFER SMT TYPE

X.±0.5	X.±5'	USE: CUSTOMER	PART NO.: L015AWR-03-B1MB2-*-2
.X±0.3	.X±2'		
.XX±0.25	.XX±1'	CHKD: 田峰	DWG NO.: GCCP-1259
--	--	DR: 蒋建银	SCALE 1 : 1
UNITS: mm		SHEET 1 / 1	

A B C D E F